



LIRA ARMCHAIR

Lira is Dynamobel's classic auditorium seat. Taking austerity as the basic concept, it was painstakingly worked on to arrive at a faultless, uncontrived, functional design. The result is a timeless, unassuming seat with warm materials and a perfect finish.



TECHNICAL SHEETS



OPTIONAL FEATURES

WRITING TABLET

Retractable tablet on arm. Only on straight legs or with armrests.

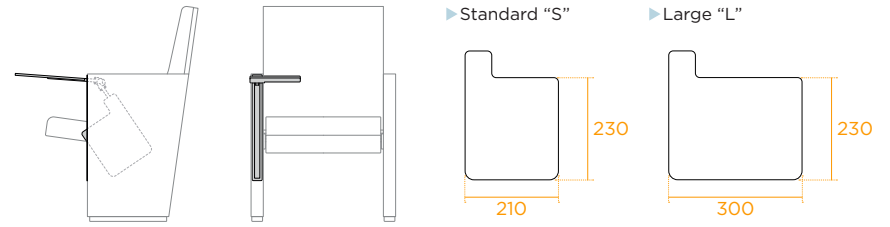

DESK

Weight= 6.5 Kg.

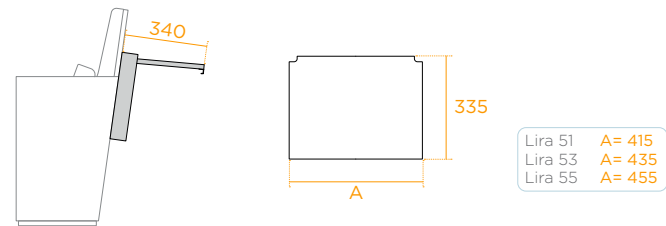

OPTIONAL FEATURES

SEAT NUMBERING

▶ Row number on leg

▶ Seat number on seat / backrest

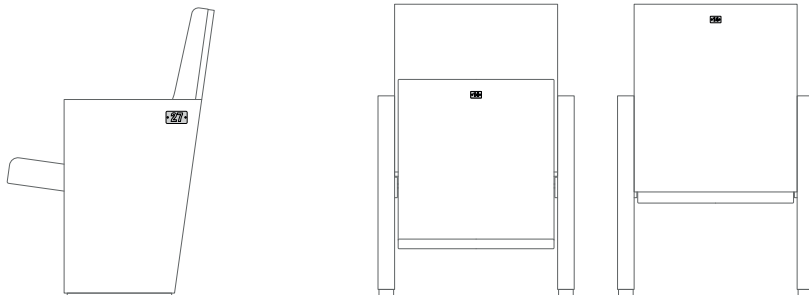

TYPES OF LEGS

▶ Fixed Floor Mount

▶ Detachable Floor Mount

▶ Angled Floor Mount



LEG SHAPES

▶ Straight

▶ Curved

▶ With armrests

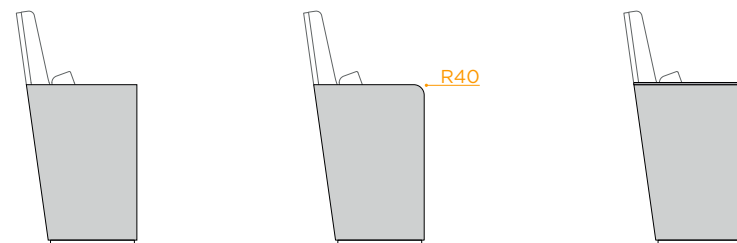



LIRA ARMCHAIR



DESCRIPTION

ARMS/LEGS

Consisting of a piece of wood 50 mm thick with different finish options in wood veneer or melamine on both sides and edged on all four sides with 2-mm edging, in wood on the wood veneer finish and in ABS in the case of melamine, all edges with a radius of 2 mm. The floor mount is used to anchor the seat to the floor. The first step of assembly consists of fixing this metal part onto which the leg is to be attached on the floor.

On the straight-leg version only, an armrest upholstered with high-density foam and black fabric is an option.

The rotating parts which allow the seat to fold are fitted on the legs. These fittings are made of glass-fibre reinforced polyamide and one or two are fitted per leg depending on whether it is right, left or intermediate.

The seat can be assembled at different angles by varying the geometry of the floor mounts, which can be adapted to the slope of the floor and the angle of the user's desired line of vision.

BACKREST

Ergonomic backrest composed of two parts:

- **Front:** a wooden support onto which combustion-modified HR foam rubber with a density of 30 kg/m³ is placed. All upholstered with a fire-resistant barrier between fabric and foam.
- **Rear:** 19-mm thick chipboard with different finish options in wood veneer or melamine on both sides and edged on all four sides with 2-mm edging, in wood on the wood veneer finish and in ABS in the case of melamine, all edges with a radius of 2 mm. The rear is fixed laterally to the legs with two 2-mm thick painted steel fittings.

SEAT

The seat consists of a 16-mm thick MDF interior base, reinforced with 2-mm thick folded sheet metal brackets with Ø12mm steel shafts welded onto them for the seat to rotate by gravity thanks to a 5-mm thick sheet metal counterweight at the rear.

40 kg/m³ combustion-modified HR foam rubber is glued to the base with water-based adhesive and the entire assembly is covered with a fire-resistant barrier and a fabric or leather cover as per order.

TECHNICAL SHEETS



DIMENSIONS

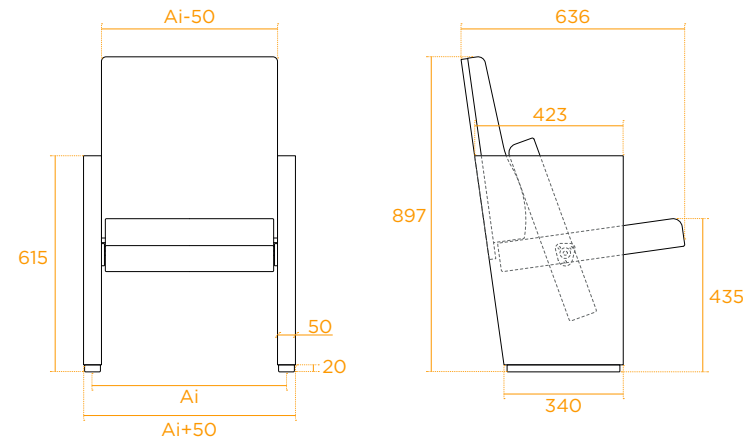

Ai	Width between axes (mm)	510 / 530 / 550
Ta	Seat fabric (m)	0,56/0,58/0,60
Tr	Backrest fabric (m)	0,49/0,49/0,49
Pa	Seat leather (m ²)	0,67/0,69/0,71
Pr	Backrest leather (m ²)	0,46/0,48/0,49

Weight LIRA 53	
Legs+Floor Mounts (kg)	8,3x2=16,6
Seat (kg)	7
Backrest (kg)	6,9
Total	30,5 kg



CERTIFICATES AND STANDARDS



Strength certificate per standard: UNE EN 12727:01
 Fire certificate per standard: UNE EN 1021-1
 UNE EN 1021-2
 Acoustics certificate per standard: UNE EN ISO 354:2004
 Empty seat sound absorption coefficient: 0.75as



Fire certificate per standard: AM18 (France)



RECYCLABILITY RATE

